

Your ideas become reality

Choosing the right alloy and defining the optimal specifications can be crucial to the success of a project. Therefore, we get together with our customers and work out the perfect solution. We do everything to realise your ideas – you'll be surprised at what is possible. You benefit directly from the years of experience and extensive know-how of our employees.

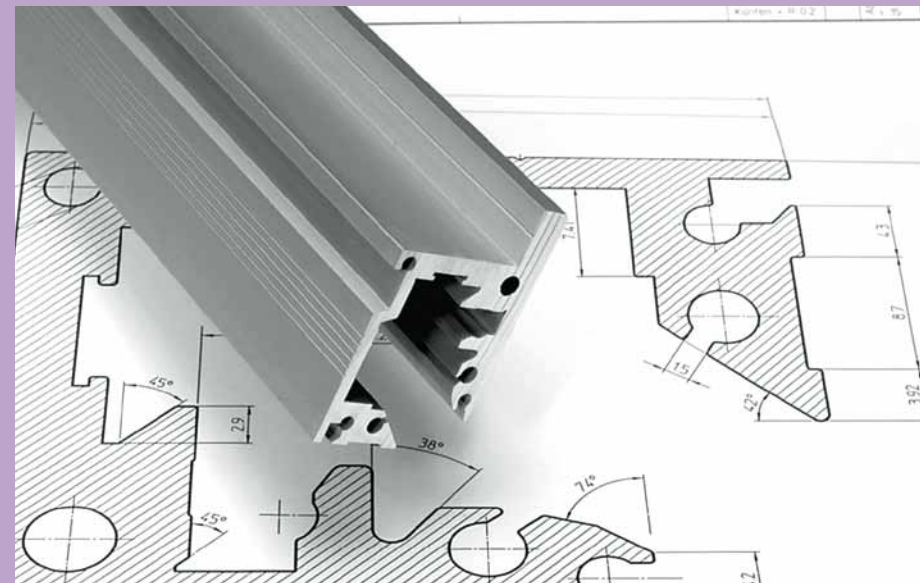

Close tolerances and surfaces with the smallest roughness are our strengths.

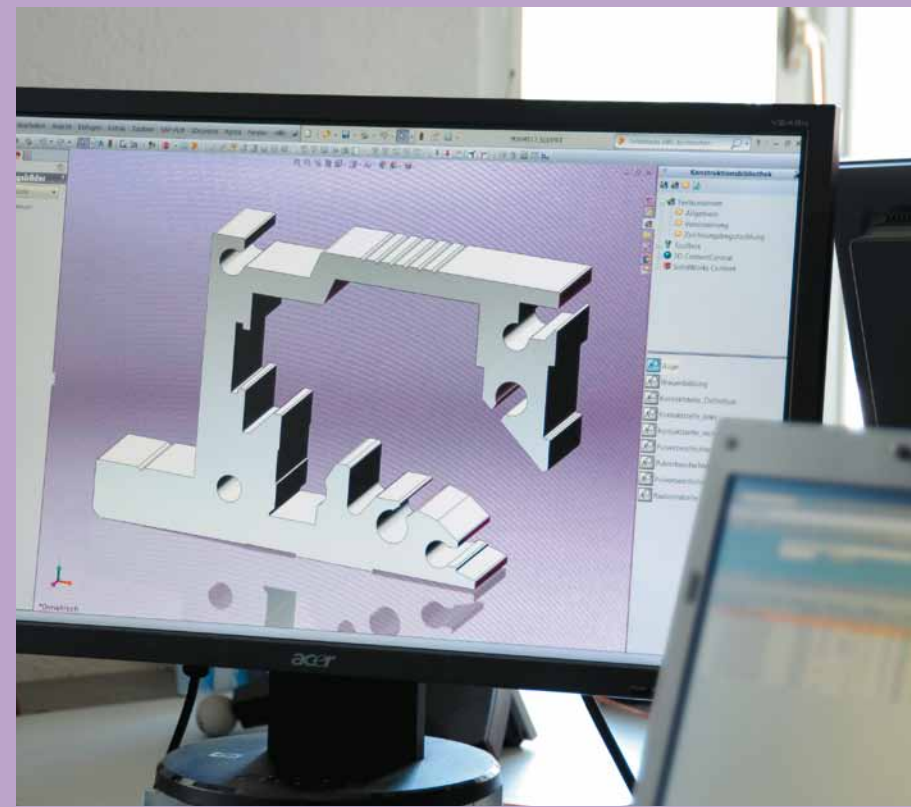
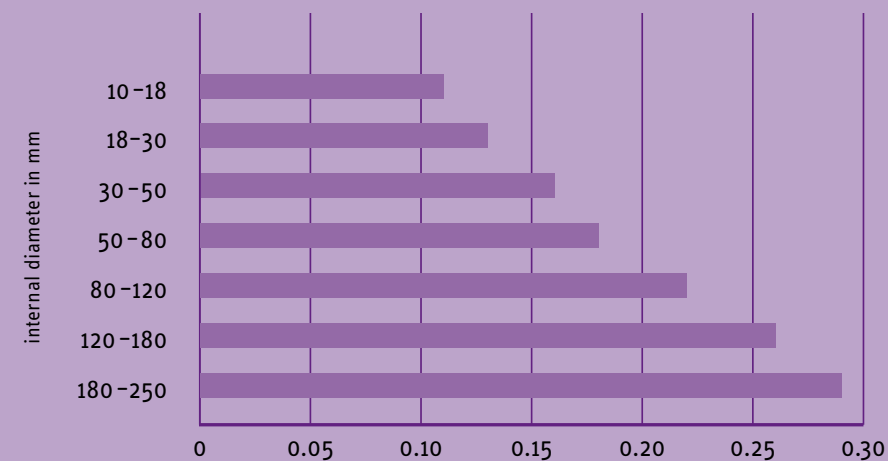

All our products and services reflect our ambition to deliver the highest quality with Swiss precision and punctuality.

A company with a cutting edge tradition

The roots of our company date back to 1897. Our ambition to adapt and to bring the latest technologies and processes to perfection has always enabled us to look to the future with optimism. Our highly experienced staff would be pleased to offer their know-how to advise you on the best implementation of your products. From idea to market. With Swiss precision and reliability.

- Extrusion —
- Surface finishing —
- CNC machining —
- Engineering —
- Specialist foundry —
- Assemblies —
- Logistics —
- Recycling —

ALU MENZIKEN

Swiss Aluminium Technology

Alu Menziken Extrusion AG
Alte Aarauerstrasse 11
CH-5734 Reinach

Tel. +41 62 765 21 21
Fax +41 62 765 21 04

www.alu-menziken.com
extrusion@alu-menziken.com

A Company of Montana Tech Components AG

PNEUMATICS

PROFILES FROM ALU MENZIKEN

Giving you a boost with aluminium

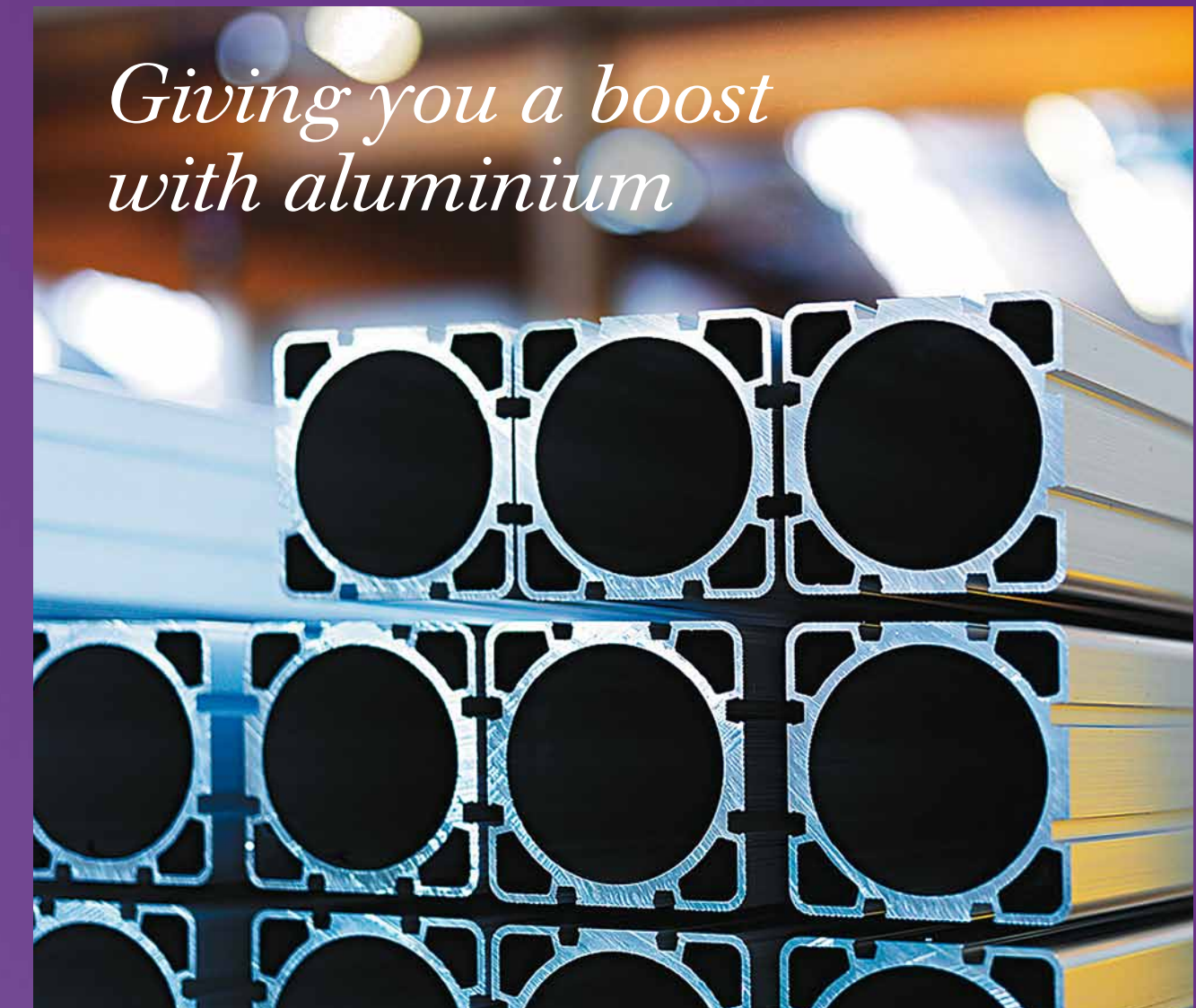

ALU MENZIKEN

Swiss Aluminium Technology

Alu Menziken is certified according to
ISO 9001, ISO/TS 16949, OHSAS 18001,
ISO 14001 und EN 9100

Our leading market position is no coincidence

When it comes to pneumatics, there is hardly any other aluminium specialist with comparable experience and expertise in the field.

Thanks to the close cooperation and partnership that we enjoy with our customers, as well as our comprehensive range of highest quality products, we have become the market leader in Europe for aluminium profiles for pneumatic applications.

The greatest range with the highest quality

Our products meet the highest requirements in terms of surface treatment and manufacturing tolerances.



The perfect product – customer-specific or standard products from stock

With our large selection of pre-fabricated products, we are able to serve many customer needs quickly, easily and inexpensively. For new developments, our specialists work closely with customers to evaluate the product properties and the optimum production process. Customized finished products are precisely manufactured from semi-finished materials, using high-performance saws and CNC machining centres. Exactly as you desire.

- Round tubes
- Profiles
- Slotted cylinders
- Surface engineering
- Linear guides



Aluminium recycling makes sense economically and ecologically

Aluminium can be recycled any number of times without any loss of quality. Moreover, because the energy consumption for recycling aluminium is only about 5 to 10% of the value for primary aluminium production, it is both economically and ecologically sensible. Hence, recycling has a high priority at Alu Menziken. On request, we can undertake the melting or the environmentally sound recycling via our network. Thus **80%** of our production now comes from recycled aluminium; and this figure is increasing every year.



Assemblies
Leave it to us

We also take on the pre-assembly of individual aluminium components, right up to complete assemblies. We deliver complete solutions at an excellent price-performance ratio, according to your requirements.



Surfaces
Because we are not superficial

The right surface treatment gives your product the finishing touch – whether for reasons of aesthetics or functionality. We are specialists in colourless anodizing, internal anodizing, powder coating and brush finishing, even for lengths of up to 13 metres.